

Model: 1000SS DCV
4" - 10"

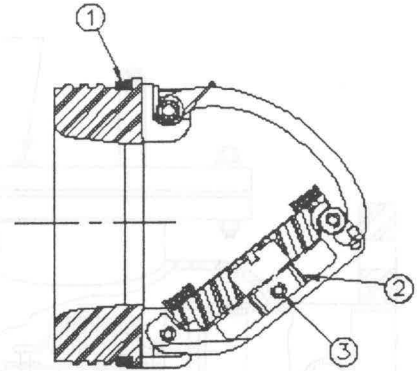
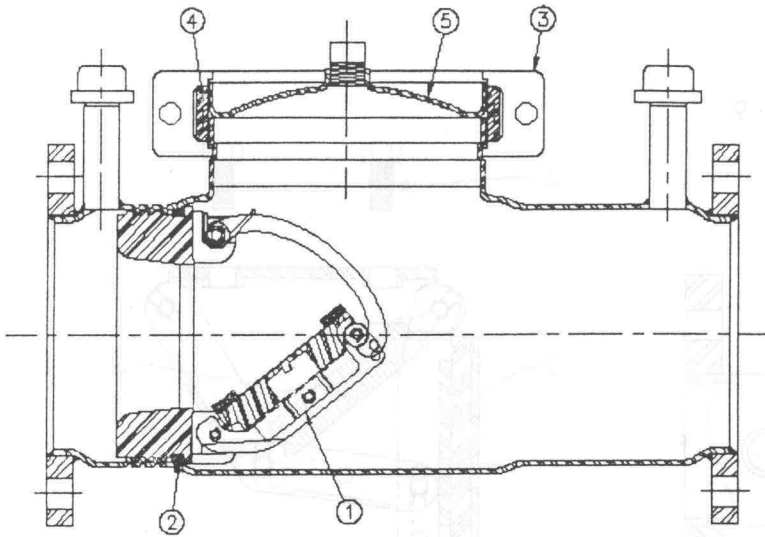

Sizes 4" & 6"

Item #	Description	Qty.	4"	6"
1.	Cam-Check Assembly	1	7015580	7016695
2.	Cam-Check O-ring (removable)	1	7013229	7013301
3.	Groove Coupler	1	7013194	7013287
4.	Groove Coupler Gasket	1	7013248	7013308
5.	Cover Plate	1	7013241	7013289

Item #	Description	Qty.	4"	6"
1.	1st Cam-Check O-ring (removable)	1	7013229	7013301
2.	Clapper Assembly (removable)	1	7016899	7016900
3.	Pivot Arm Pin (removable) 2 c-clips	1	7013853	7013841

Item #	Description	Qty.	8"	10"
1.	Knuckle Joint Assembly (complete unit)	1	7015552	7015552
2.	Clapper Plate w/link	1	7011413	7011413
3.	Spring	3	7011323	7011323
4.	3/8" Stainless Steel Bolts	1	7014619	7014619
5.	Washer (not shown)	1	7014585	7014585
6.	Bronze Seat (replaceable in line)	1	7011163	7011163
7.	Seat O-ring	2	A300706	A300706
8.	Cover Plate	1	7011016	7011016
9.	Groove Coupler	1	A605530	A605530
10.	Clapper Retainer Clip (not shown)	1	7013913	7013913

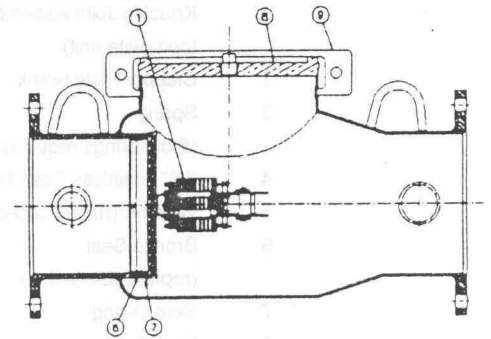

8" & 10"
Sizes

KNUCKLE JOINT ASSEMBLY #1

